



# Above Ground System

---

## Description

Insapipe Above Ground is a range of thermally insulated piping systems, factory manufactured under stringent production and quality control conditions. It is suitable for use at process pipe temperatures between - 50°C and +130°C in any above ground environment. Insapipe Above Ground offers a high efficiency thermal insulation coupled with the ultimate vapour barrier and weather protection. This family of products provides an extremely robust waterproof insulation system, so robust that the insulation can safely support the weight of the pipe and its contents. Insapipe Above Ground can therefore be hung from its outer casing. Hangers or brackets do not penetrate the outer casing causing potential points of vapour ingress.

Insapipe Above Ground is available in the casing of your choice utilizing any pipe required. Insapipe Above Ground is manufactured from three basic components: pressure tight casing, the required process pipe and rigid polyurethane foam. The process pipe is centralized within the outer casing and the resultant annular space between the casing and the process pipe is machine-filled with polyurethane foam. The polyurethane foam expands and, upon setting, forms a dense homogenous insulation around the pipe.

Special systems are available for cryogenic services.

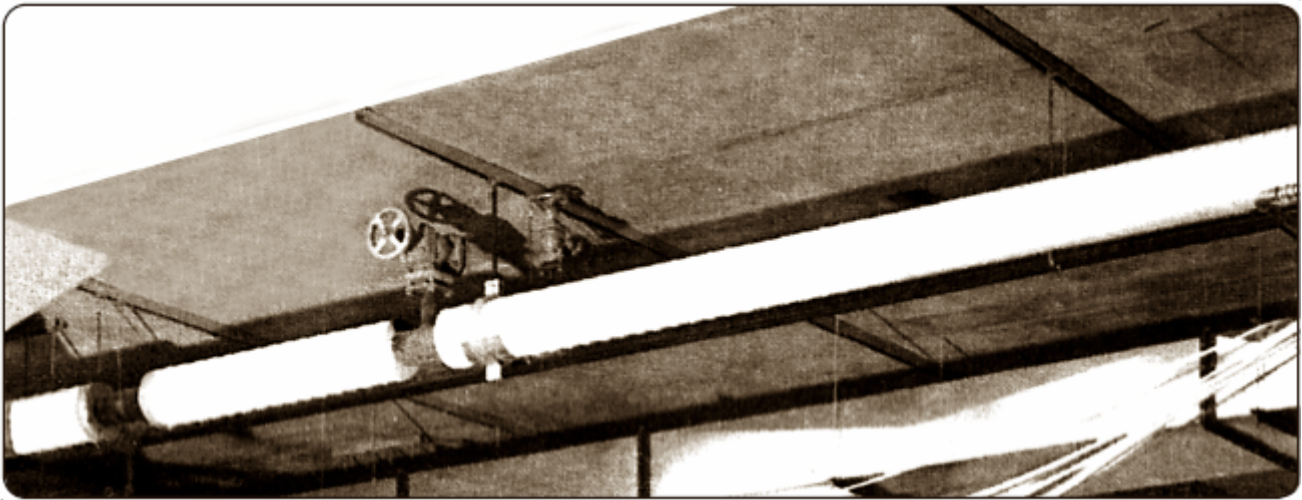

## Quality Control

Insapipe Above Ground is manufactured to strict QC requirements which require a considerable amount of laboratory and experimental testing. Testing of raw materials as listed below together with typical water tightness data are available on request.

Non-destructive testing of steel pipe welds.

Pressure testing of process pipe.

Thermal conductivity of insulation.

Thermal aging of insulation.

Mechanical properties of casing materials.

Mechanical properties of completed foam system.

Biological properties of foam system.

Physical properties of completed system.

Tests on typical field joints under cyclic thermal conditions under external water pressure head.

System test in which a representative pipe circuit is subjected to cyclic thermal conditions under external water pressure head.

A strict regimen of quality control procedures is maintained to ensure that every product made conforms to our minimum standards.

---



# Above Ground System

## Alternative Components

Insapipe Above Ground comes with the following components: Straight Lengths, L Bends, Straight Tees, Crossover Tees, Anchors and MiniBends. All are available pre-fabricated, or as kitsets to assemble on site or in your own factory.

This provides three basic systems:

## Site System

Supplied in pre-insulated straight lengths. Bends, tees and straight joint casings are supplied in kitset form and fitted as the pipeline is installed. The on-site insulation of these fittings being carried out after pressure testing.

## Unitised System

Supplied in pre-insulated straight lengths, bends and tees of standard dimensions. The only site insulation required is the straight joints between units.

## Pre-fabricated System

Supplied in pre-insulated pipe lengths, branch off takes and bends to specific dimensions and configurations, custom manufactured to individual requirements.

This system dramatically reduces on-site installation costs and reduces site installation to straight joints between pre-fabricated units.

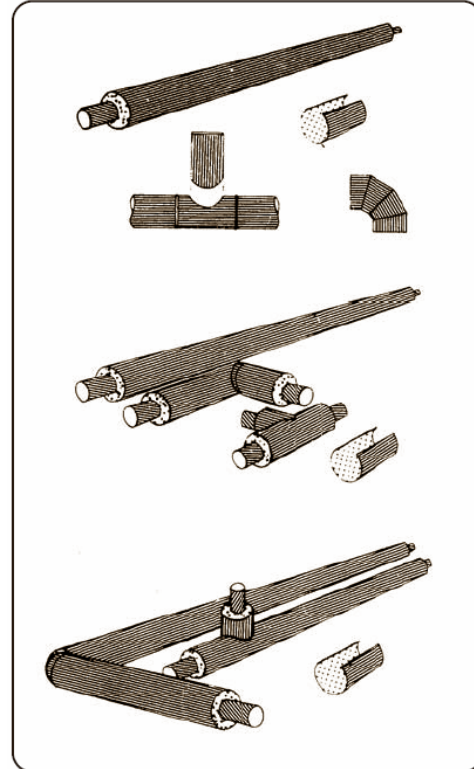

## Fire Behaviour

- 1. CEBS – Australia report TR/44/153/41** - Fire Behavior of Pipe Insulation System under a forced draft vertical shaft developing fire situation. This test reported zero flame spread for Spiral Wound Galvanised Cased Insapipe.
- 2. BRANZ Test Report FP748:** Behaviour of Spiral Wound Galvanised Cased Insapipe exposed to a fully developed fire, duration - 1 hour. This test simulates the system under modification or installation with exposed foam faces at an un-insulated tee. Test results showed no sign of fire or flame from the casing outside the region exposed to the fire, nor deterioration of the pipe system further than 1 metre from the system exposed to the fire.
- 3. BRANZ Test Report 802:** Spiral Wound Galvanised Cased Insapipe behaviour exposed to a fully developed fire, duration - 2 hours. This test subjects the system to temperatures exceeding 1000°C. Test results showed no sign of fire or flame from the casing outside the region exposed to the fire and no deterioration of the casing situated inside the insulated enclosure, exposed to the full force of the fire.

- 4. BRANZ Test Report No. FE717:** Test on a simulated Spiral Wound Galvanised Cased Insapipe System utilising Australian Standard AS1530 Part 3 1976 “Early Fire Hazard Properties of Materials”. This test yielded zero indices for ignitability, spread of flame, heat evolved and smoke developed.

Copies of CEBS Report TR/44/153/41 and BRANZ Reports Nos. FP748, FP802 and FE717 available on request.

Although Spiral Wound Polyester Coated Steel Cased Insapipe has not been subjected to similar fire performance tests, any results obtained would parallel those achieved above.

Note: Polyethylene Plastic cased Insapipe should not be used in situations where flame spread is a concern, particularly in vertical orientations.

## Casing Alternatives

The following selection enables a casing to be chosen which will be functional, aesthetically pleasing and most suited to the environment.

Plain spirally wound locked seam pipe. Galvanised 150g/m<sup>2</sup> minimum spangle chromated of .45mm (26 gauge) for sizes up to 200mm diameter and .6mm (24 gauge) for sizes from 225mm diameter (other gauges available on request).

Material Options: galvanised steel  
stainless steel  
aluminium

As above but polyester powder coated white, oven cured at 200°C. This casing provides a tough durable high gloss surface, highly resistant to chipping, scratching and surface abrasions.

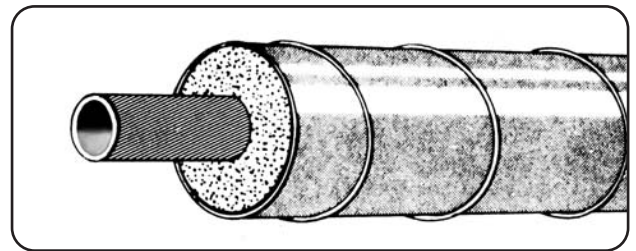

This system also incorporates a protective sleeving to guard against damage during installation. It is recommended that this sleeving be left in place until completion of the installation and site insulation.

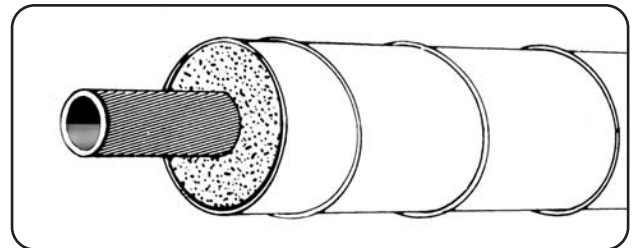

High density polyethylene (HDPE) Type 50 to BS 3284/67 Black in colour. Customarily recognised as an underground casing, HDPE is equally suited for above ground systems.

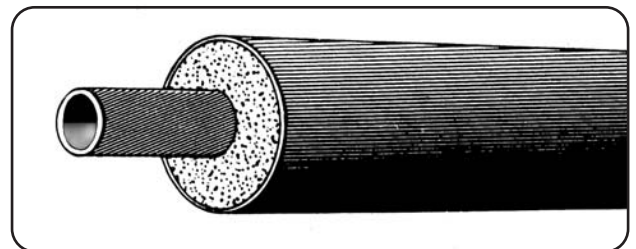

### CASING CHARACTERISTICS

Corrosion resistance  
Resistance to sunlight  
Vapour barrier  
Resistance to mechanical damage

### Plain Spiral

Good  
Excellent  
Excellent  
Good

### Spiral Coated

Very Good  
Excellent  
Excellent  
Good

### Polyethylene

Very Good  
Excellent  
Excellent  
Excellent

Alternative casings available if required.



# Above Ground System

## Suggested Form of Specification

### Pipework

Insulation shall be "Insapipe" process pipe in casing without air gap, or approved equivalent of the physical properties indicated below. This material must be installed strictly in accordance with the manufacturer's recommendation's.

#### 2.1 Process Pipe

The pipe shall be suitable for the pressure service specified elsewhere. All pipes shall have ends suitably prepared for welding and shall be capped for transport and storage .

#### 2.2 Outer Casing:

Shall be spiral formed locked seam galvanised steel type of the following gauges—

Up to 200 nb dia    26 gauge  
225 nb and over    24 gauge

#### 2.3 Finish:

Plain galvanised steel spangle chromated.

#### 2.4 Insulation:

Insulation shall be methylene di-isocyanate (MDI) based rigid polyurethane foam machine injected into the annulus between process pipe and casing by a one shot factory process and shall have the following physical properties:

2.4.1. Density:  
60 kg/m<sup>3</sup> min.

2.4.2. Thermal Conductivity:  
k value 0.023 W/m<sup>2</sup>K at 20°C mean.

2.4.3. Compressive Strength:  
275 kPa minimum.

2.4.4. Closed Cell Content:  
90% by volume minimum.

#### 2.5 Completed System:

2.5.1. Water vapour permeability  
1.8 x 10<sup>-5</sup> metric perms

2.5.2. Fire Rating: 2 hrs at 982°C and shall be certified to the approval of the relevant authority.

#### 2.6 Thickness of Insulation:

Shall be of such thickness as to prevent condensation forming on the outer casing under following conditions:

Ambient Temp	Rh%	Fluid Temp
35° C	90	6°C
30° C	95	6°C

#### 2.7 Installation

2.7.1. Joints between pre-insulated units bends and valves are to be insulated in situ and correctly vapour sealed.

2.7.2. Particular attention is drawn to the following topics covered by the manufacturer's recommendation and must be strictly adhered to.

Handling and Storage.  
Supports, Hangers and Anchors.  
Provision for Contraction and Expansion.

## Bend Joint

### Kitset contains

- 1 x Bend casing
- 2 x Casing sleeves
- 2 x Plastic spacers
- 1 x Pour hole cap
- 1 x tube vapour sealant mastic
- Pop rivets

### Procedure

1. Position and weld the long radius welding elbow using a heat shield to protect the foam faces.
2. Cut the spacers to the correct size and fit adjacent to the welds.
3. Match mark and breakdown the bend casing into segments.
4. Re-assemble the bend in position on the pipe applying vapour sealing mastic into the swaging provided on all circumferential and longitudinal seams. Use pop rivets provided.
5. Position the bend casing on its spacers, assuring it is concentric with the casing on both legs.
6. Apply vapour sealing mastic to internal surfaces of longitudinal and circumferential swages of the casing sleeves.

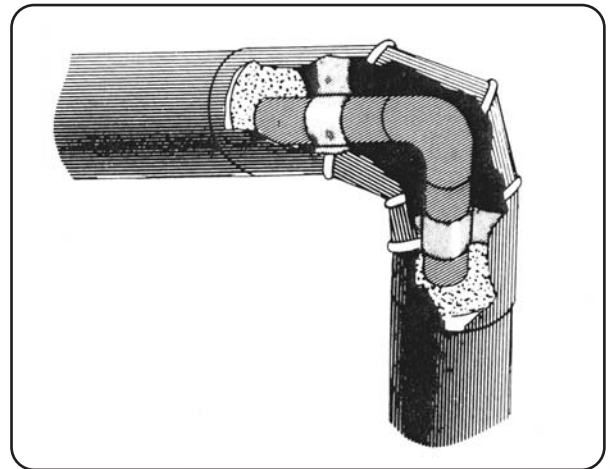

7. Position the casing sleeves and pop rivet into place, tapping down swages where necessary.
8. Drill pour hole, air holes and mix and pour foam. (See Polyurethane Foam Pouring Procedure).

NOTE: When pipe is over 100 nb, spacer components are provided requiring assembly on the pipe.

## Tee Joint

### Kitset contains

- 1 x Mainline casing sleeve
- 1 x Branch casing sleeve
- 1 x tube vapour sealing mastic
- 1 x Pour hole cap
- Pop rivets

### Procedure

1. Mark the required tee position on the casing and measure 150-175mm maximum either side of your mark and scribe a cutting line.
2. Using a hacksaw cut through the casing at the cutting line, then cutting diagonally across the section now isolated, remove the unwanted casing and foam. Key points: Do not cut into the service pipe. Use a knife to remove the foam.
3. Complete tee weld. Key point: Position heat shields at exposed foam face prior to welding.
4. Apply vapour mastic to seams on main sleeve and position over tee. Pop rivet main way sleeve on to casing.
5. Apply vapour sealing mastic to internal surface of longitudinal and circumferential swages on branch sleeve.

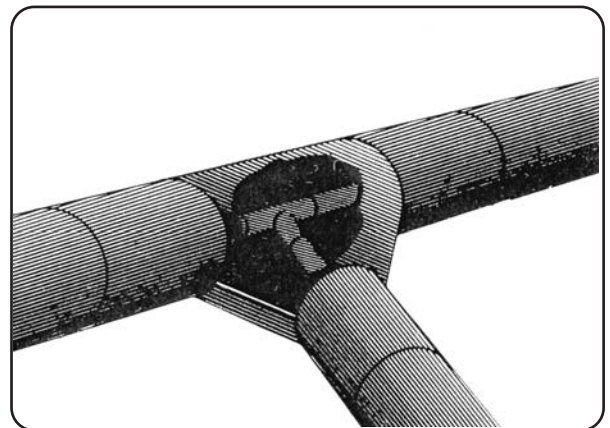

6. Position and pop rivet branch sleeve over both casing and tee sleeve assuring main sleeve is concentric in both places.
7. Drill pour hole, air holes and mix and pour foam as above.

## Cone Joint

### Kitset contains

- 1 x Cone
- 1 x Casing-sleeve
- 1 x Vapour sealing mastic (tube)
- 1 x Pour hole cap
- Pop rivets

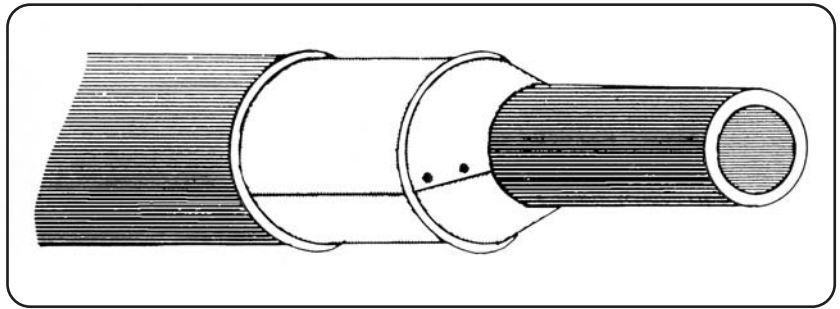

### Procedure

1. Separate the sleeve casing and cone.
2. Apply the vapour sealing mastic to the internal surfaces of the longitudinal and circumferential swages of the casing sleeve. Ensure the sealant is applied in a continuous even bead and kept clean .
3. Apply vapour mastic to cone overlap.
4. Fit cone over pipe and apply bead of vapour mastic on the inside of overlap only.
5. Position cone 185mm from the end of the exposed insulation face and rivet the overlap of the cone.
6. Position the casing sleeve as shown, rivet into position and tap down swages as necessary to ensure a tight seal is obtained.  
Key points: Engage end swage of casing sleeve over cone. Ensure 25mm overlap back to pre-insulated casing.
7. Drill a 25mm pour hole  
Key point: Locate pour hole on uppermost side of casing to facilitate pouring.
8. Mix and pour foam.  
(See Polyurethane Foam Pouring Procedure).
9. Using a soft rag clean residual foam and vapour mastic off the casing.
10. To seal the pour hole apply the vapour mastic sealant to the underside of the pour hole cap and pop rivet over the pour hole.

## Valve Joint

### Kitset contains

- 2 x Standard cones to suit casing O.D.
- 1 x Oversize casing sleeve
- 2 x Transition cones
- 1 x Vapour sealing mastic (tube)
- Pop rivets

### Procedure

1. Fit vapour seal and insulate the standard cones from casing to pipe. (Refer to Cone Joint Procedure above).  
Fit and vapour seal the transition cones to the casing.
2. Measure valve bonnet and cut sleeve casing to suit at longitudinal joint.
3. Insulate valve with glass fibre blanket up to approximately 20mm thicker than the internal diameter of the casing sleeve.  
Key point: Strap blanket into position.
4. Vapour seal the swages of the oversize casing sleeve .
5. Fit the oversize casing sleeve into position connecting to the transition cones and compressing the glass insulation in doing so.
6. Pop rivet the casing sleeve to the transition cones.
7. Lay a fillet of vapour sealing mastic around the valve bonnet and hole in the casing sleeve.

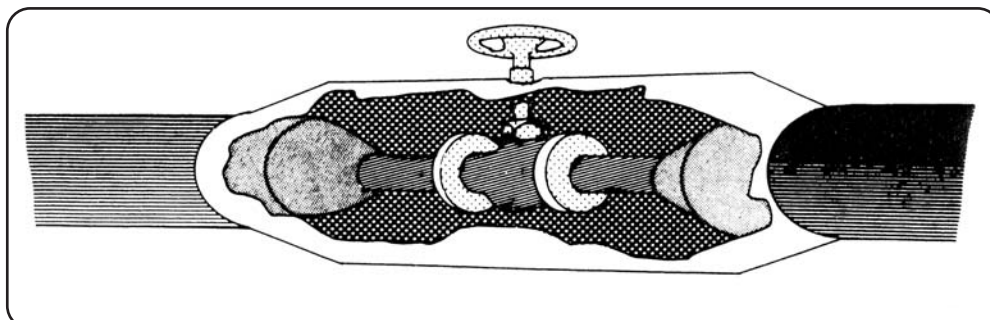

## Straight Joint

### Kitset contains

- 1 x Casing sleeve
- 1 x Tube vapour sealant mastic
- 1 x Pour hole cover
- Pop rivets

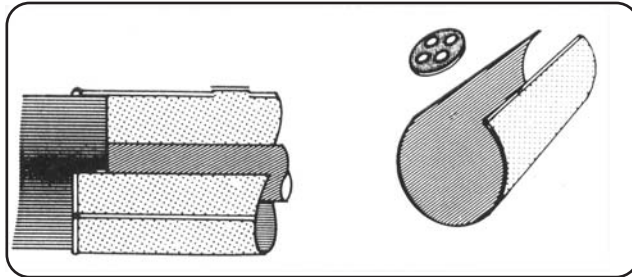

### Procedure

1. Weld pipes as normal.  
Key point: Position heat shields at exposed foam faces prior to welding.
2. Apply the vapour sealing mastic to the internal surfaces of the longitudinal and circumferential swages of the casing sleeve. Ensure the sealant is applied in a continuous even bead and kept clean.
3. Centralise the casing sleeve over the joint and pop rivet into position. Tap down swages as necessary to ensure a tight seal is obtained.  
Key points: Overlap the swages, and position them facing downwards and away from view if possible. Rivet centres no greater than 75mm.
4. Drill a 25mm pour hole and two 3mm air holes.  
Key points: Locate pour holes on uppermost side of casing to facilitate pouring. Locate air holes adjacent to the highest foam face.
5. Mix and pour foam.  
(See Polyurethane Foam Pouring Procedure).
6. Remove excess foam from air holes, clean and seal with pop rivets.
7. Using a soft rag clean residual foam and vapour mastic off the casing.
8. To seal the pour hole apply the vapour mastic sealant to the underside of the pour hole cap and pop rivet over the pour hole.

## Anchor Installation Procedure

### Uninsulated

1. Mark the required anchor position on the casing and measure 150-175mm maximum either side of your mark, Scribe cutting lines.
2. Using a hacksaw cut through the casing at the cutting lines then cutting diagonally across the section now isolated, remove the unwanted casing and foam.
3. Weld anchor as specified in place.
4. Seal off exposed foam faces either side of anchor with cones (See Cone Joint Procedure)

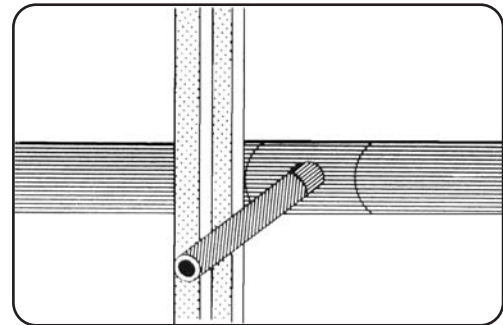

### Insulated

1. Select a stub of pipe of the same diameter as the process pipe and slightly atten one end to simplify welding.
2. Refer un-insulated anchor Step 1.
3. Refer un-insulated anchor Step 2.  
Key points: Do not cut into the process pipe. Use a knife to remove the foam.
4. Weld the pipe stub to the process pipe.  
Key point: Use two heat shields positioned at exposed foam face.
5. Take a standard straight joint casing sleeve and mark out a hole centrally 10mm smaller than the stub O.D.  
Key point: Ensure hole position is such that the lap is either at 4 or 8 o'clock.
6. Cut the hole out and swage the edge of the hole with a ball pein hammer to ensure a tight št over the pipe stub.
7. Apply a šlet of vapour sealing mastic to the inside edges of the swaged hole, and to longitudinal and circumferential swages of the casing sleeve.
8. Position the casing sleeve over the stub anchor, rivet into place and tap down swages as necessary to ensure a tight seal is obtained.  
Key points: Position the swage lap over the single swage, facing downwards and away from view if possible. Rivet centres no greater than 75mm.
9. Insulate anchor  
(See Polyurethane Foam Pouring Procedure).



# Above Ground System

## Access

Sufficient access is required to enable on-site insulation. To facilitate this function the minimum space required surrounding the item to be insulated is shown in insert alongside.

## Expansion

Where the expansion is to be taken into the bends, normal expansion criteria should be used to ensure that the service pipe is not overstressed at the bends.

Where expansion bellows or loops are used to cater for expansion, no special allowances are required for using Insapipe Above Ground. However, if long straight pipe runs are considered, we would highlight the fact that consideration should be given to the expansion stress imposed on the foam and outer casing. This stress criterion depends on many factors but generally expansion into any bend, loop or bellows should be limited to approximately 25mm of expansion (i.e. 60 metres between bends, loops or bellows at an operating temperature of 80° C).

If movement calculated exceeds the 25mm allowed then provision must be made to accept this movement by providing a loop offset bellows or other mechanical expansion joint.

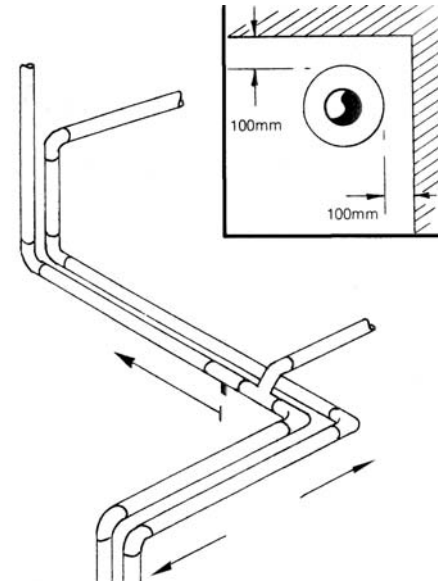

$$\text{Change in length} = \text{original length} \times \text{coefficient of linear expansion} \times \text{temperature difference}$$

$$m = m \times m/m^{\circ}C \times ^{\circ}C$$

Material	Coefficient of linear expansion
Steel	$12 \times 10^{-6}$
Copper	$17 \times 10^{-6}$
PVC	$8 \times 10^{-5}$

## Process Pipe Selection and Supply

Insapipe Above Ground can incorporate any specified type of process pipe of any length with due regard to handling and transport. We will be pleased to supply your specified pipe or alternatively, clients may wish to supply their own process pipe

## Pipe Supports

Insacled is a rigid insulation system capable of being supported on the outer casing in a number of ways.

Care should be taken in designing supports to ensure that the loads are distributed over an acceptable area. The compressive strength of the foam is quoted at 320 KPa but this strength varies as temperature creases.

It is recommended that supports and hangers be designed based on a safe compressive strength of 170 KPa taken over the bottom third of the casing for applications where temperatures are unlikely to exceed 100° C and for temperatures over 100° C a safe compressive strength of 100 KPa over the bottom third of the casing.

